

複動型—標準行程表：

| 氣缸內徑 | 行程 (mm) |
|---------|---|
| φ 20,25 | 5, 10, 15, 20, 25, 30, 40, 50, 60, 80, 100, 200 |
| φ 32,40 | 5, 10, 15, 20, 25, 30, 40, 50, 60, 80, 100, 200, 300 |
| φ 50,63 | 10, 15, 20, 25, 30, 40, 50, 60, 80, 100, 200, 300, 400 |
| φ 80 | 15, 20, 25, 30, 40, 50, 60, 80, 100, 200, 300, 400, 500 |



● 非標準行程亦可承製，請洽業務人員。

氣缸 / 訂購代號：※特殊規格訂購請參 N-03、04 頁。

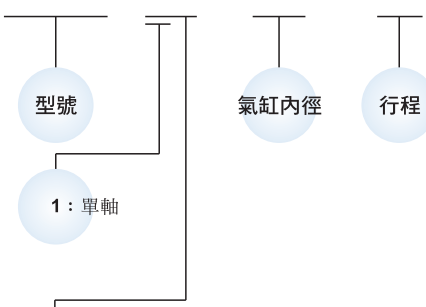
MCJI - 12 - 20 - 25



作動方式／桿端牙型：

| 代號 | 記號 | 說明 |
|-----|---|------|
| 1 1 |  | 複動外牙 |
| 1 2 |  | 複動內牙 |

特點：

- 符合 ISO 21287 標準。
- 於缸體擠製時，於外圍預留裝配槽；使傳感器在安裝固定及位置調整時，均極其簡單。
- 精巧固定設計，RCI 傳感器固定於本體上不突出，也不佔空間。
- 全系列均附磁。

規格：

| 型號 | MCJI | |
|-------------|------------------|--------------------|
| 作動方式 | 複動型 | |
| 氣缸內徑(mm) | 20, 25 | 32, 40, 50, 63, 80 |
| 配管口徑尺寸 | M5×0.8 | G1/8 |
| 使用流體 | 空氣 | |
| 使用壓力範圍 | 0.05~1 MPa | |
| 耐壓力 | 1.5 MPa | |
| 使用速度範圍 | 50~500 mm/sec | |
| 給油 | 不需給油 | |
| 緩衝方式 | 橡膠緩衝 | |
| 行程長度公差 (※1) | +0 ~ +1.0mm | |
| 周圍溫度 | -5°C~+60°C (不凍結) | |
| 傳感器 (※2) | RCI | |

※1. 行程長度公差不含緩衝墊片的變化量。



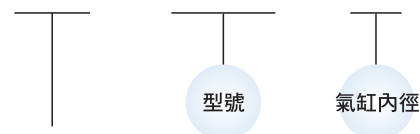

※2. 傳感器詳細規格請參 Y-10 頁 (RCI)。

安裝配件：

FAC - MCJI - 20



安裝型式：

| | |
|---|-----|
|  | LB |
|  | FAC |
|  | FBC |
|  | MP |

傳感器安裝：

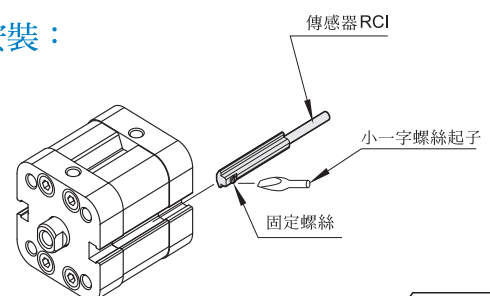

MCJI 內部構造及主要零件

薄型（治具）氣壓缸

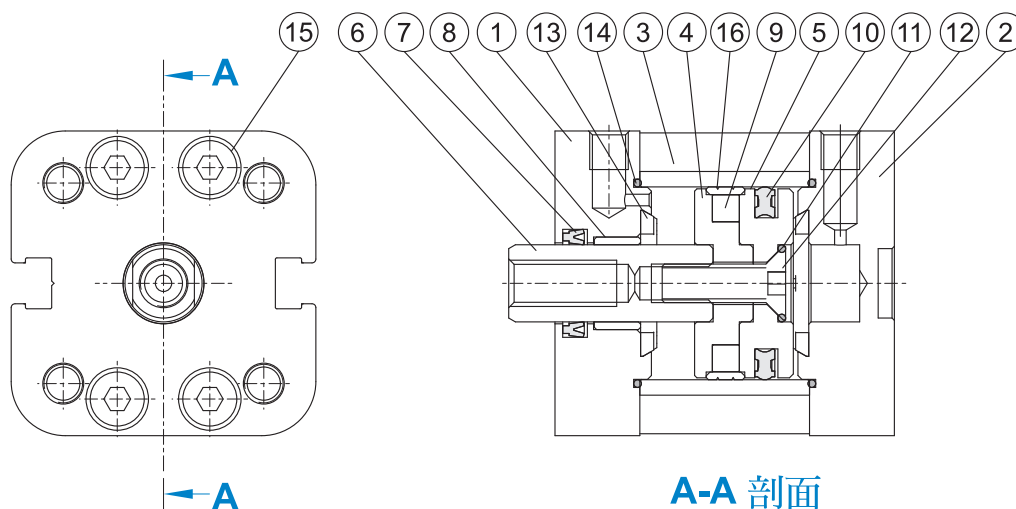

主要零件材質：





| No. | 零件名稱 | 材質 | 數量 | 不含衝程料件 (內含) | 修理包 (內含) |
|-----|----------|------|----|----------------|-------------|
| 1 | 前蓋 | 鋁合金 | 1 | ● | |
| 2 | 後蓋 | 鋁合金 | 1 | ● | |
| 3 | 本體 | 鋁合金 | 1 | | |
| 4 | 前活塞 | 鋁合金 | 1 | ● | |
| 5 | 後活塞 | 鋁合金 | 1 | ● | |
| 6 | 活塞桿 | 中碳鋼 | 1 | | |
| 7 | 活塞桿密封環 | NBR | 1 | ● | ● |
| 8 | 襯套 | 軸承合金 | 1 | ● | |
| 9 | 磁性環 | 磁石材 | 1 | ● | |
| 10 | 活塞密封環 | NBR | 1 | ● | ● |
| 11 | O 型環 | NBR | 1 | ● | |
| 12 | 皿頭六角承窩螺栓 | 碳鋼 | 1 | ● | |
| 13 | 緩衝墊片 | NBR | 2 | ● | |
| 14 | O 型環 | NBR | 2 | ● | ● |
| 15 | 六角承窩螺栓 | 不銹鋼 | 8 | ● | |
| 16 | 耐磨環 | 鐵弗龍 | 1 | ● | |

不含衝程料件 / 修理包 訂購代號：

| 內徑 | 不含衝程料件 | 修理包 |
|------|------------|------------|
| φ 20 | CP-MCJI-20 | PS-MCJI-20 |
| φ 25 | CP-MCJI-25 | PS-MCJI-25 |
| φ 32 | CP-MCJI-32 | PS-MCJI-32 |
| φ 40 | CP-MCJI-40 | PS-MCJI-40 |
| φ 50 | CP-MCJI-50 | PS-MCJI-50 |
| φ 63 | CP-MCJI-63 | PS-MCJI-63 |
| φ 80 | CP-MCJI-80 | PS-MCJI-80 |

重量表：

(單位：g)

| 型號 | 基本重量 MCJI-11 | 每10mm 行程 MCJI-11 | 基本重量 MCJI-12 | 每10mm 行程 MCJI-12 |
|------|---|---|---|---|
| 內徑 |  |  |  |  |
| φ 20 | 121 | 14 | 108 | 14 |
| φ 25 | 147 | 18 | 135 | 18 |
| φ 32 | 238 | 24 | 214 | 24 |
| φ 40 | 322 | 32 | 291 | 32 |
| φ 50 | 493 | 46 | 455 | 46 |
| φ 63 | 703 | 48 | 667 | 48 |
| φ 80 | 1,260 | 76 | 1,190 | 76 |

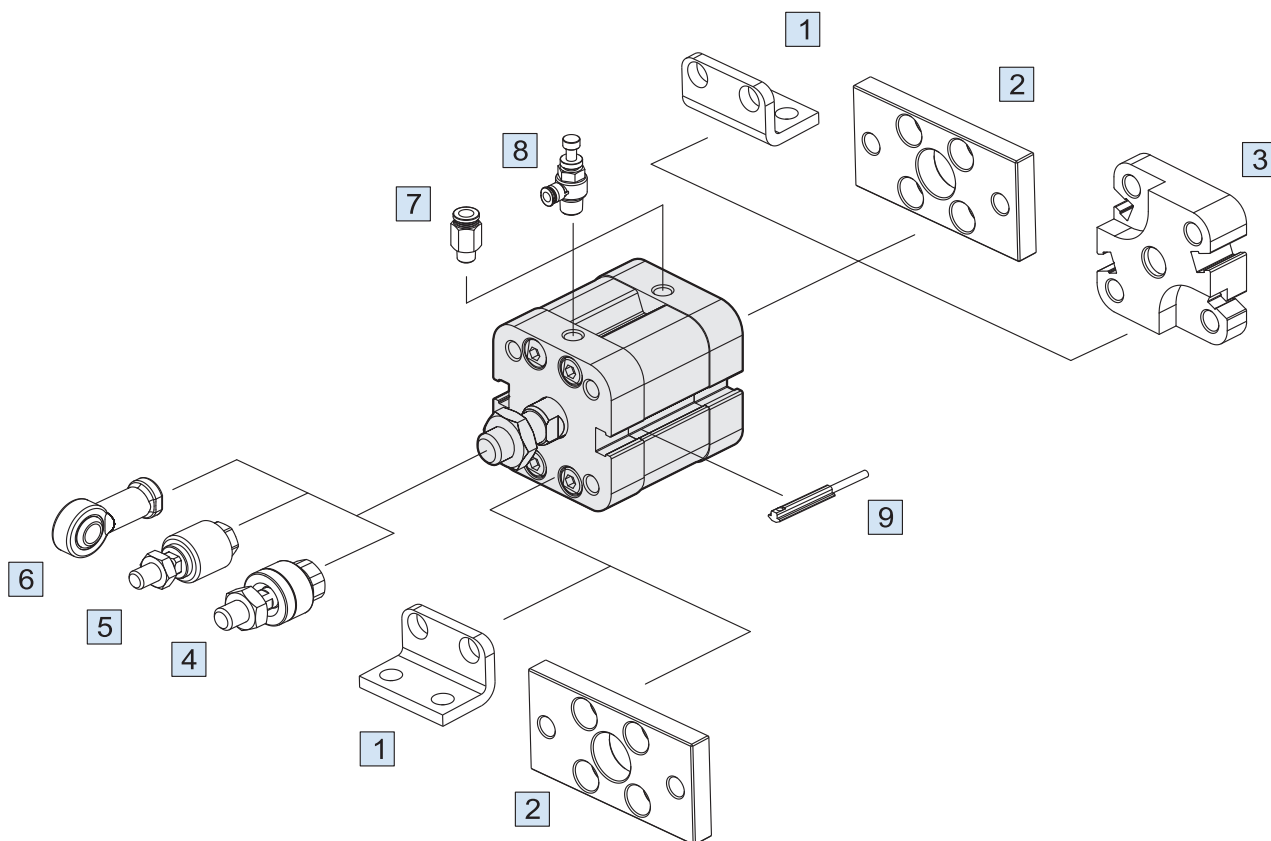

| No. | 安裝配件 | 頁次 |
|-----|-----------------|----------|
| 1 | LB 安裝配件 | O-27 |
| 2 | FAC/FBC 安裝配件 | O-27, 28 |
| 3 | MP 安裝配件 | O-28 |
| 4 | MFC 浮動接頭 | Y-01 |
| 5 | MFCS 浮動接頭 | Y-03 |
| 6 | PHS 魚眼接頭 | Y-04 |
| 7 | PC 管接頭 (PISCO) | L-02 |
| 8 | JSC 調速器 (PISCO) | L-22 |
| 9 | RCI 傳感器 | Y-10 |

φ 20, φ 25

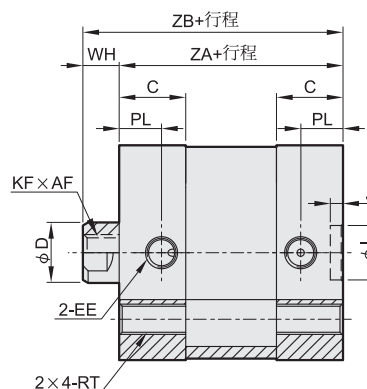
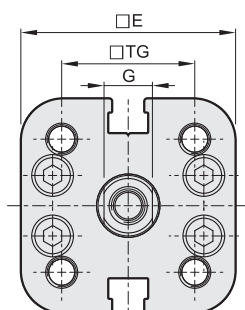

φ 32~φ 80

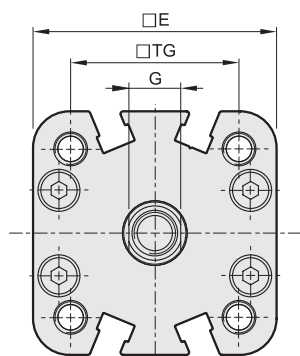

MCJQ-11(桿端外牙)

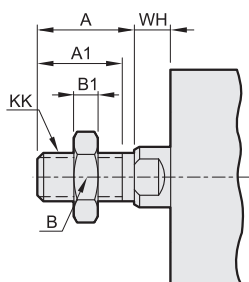

| 代號 內徑 | A | A1 | B | B1 | KK |
|----------|----|----|----|----|----------|
| 20 | 16 | 14 | 13 | 4 | M8×1.25 |
| 25 | 16 | 14 | 13 | 4 | M8×1.25 |
| 32 | 19 | 17 | 17 | 5 | M10×1.25 |
| 40 | 19 | 17 | 17 | 5 | M10×1.25 |
| 50 | 22 | 20 | 19 | 6 | M12×1.25 |
| 63 | 22 | 20 | 19 | 6 | M12×1.25 |
| 80 | 28 | 26 | 24 | 8 | M16×1.5 |

| 代號 內徑 | AF | C | D | E | EE | G | WH | I | J | KF | PL | TG | RT | ZA | ZB |
|----------|----|------|----|------|--------|----|----|----|-----|----------|-----|------|---------|----|----|
| 20 | 14 | 11 | 10 | 35.5 | M5×0.8 | 8 | 6 | 9 | 2.1 | M6×1.0 | 7 | 22 | M5×0.8 | 37 | 43 |
| 25 | 14 | 11 | 10 | 39.5 | M5×0.8 | 8 | 6 | 9 | 2.1 | M6×1.0 | 7 | 26 | M5×0.8 | 39 | 45 |
| 32 | 15 | 14 | 12 | 47 | G 1/8 | 10 | 7 | 9 | 2.1 | M8×1.25 | 7.5 | 32.5 | M6×1.0 | 44 | 51 |
| 40 | 15 | 14 | 12 | 54.5 | G 1/8 | 10 | 7 | 9 | 2.1 | M8×1.25 | 7.5 | 38 | M6×1.0 | 45 | 52 |
| 50 | 18 | 14 | 16 | 65.5 | G 1/8 | 14 | 8 | 12 | 2.6 | M10×1.5 | 7.5 | 46.5 | M8×1.25 | 45 | 53 |
| 63 | 18 | 14.5 | 16 | 75.5 | G 1/8 | 14 | 8 | 12 | 2.6 | M10×1.5 | 7.5 | 56.5 | M8×1.25 | 49 | 57 |
| 80 | 20 | 15.5 | 20 | 95.5 | G 1/8 | 17 | 10 | 12 | 2.6 | M12×1.75 | 8 | 72 | M10×1.5 | 54 | 64 |

LB

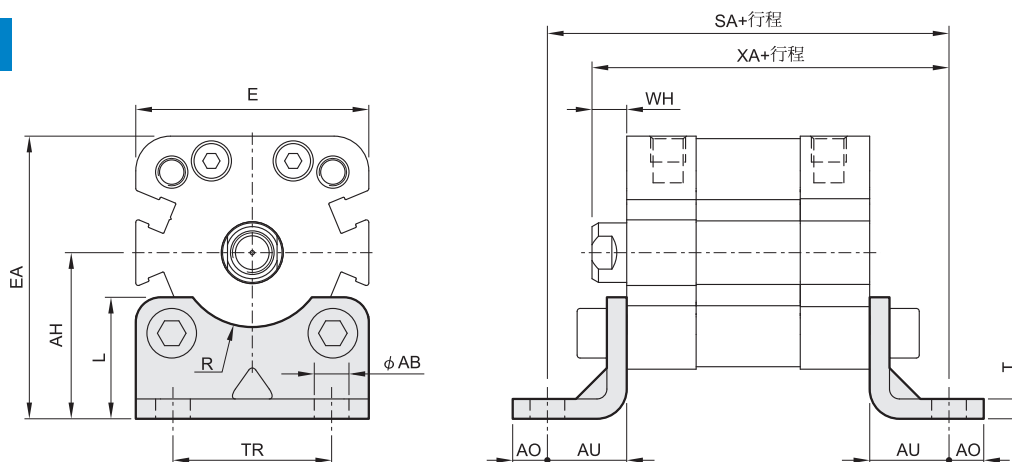

| 代號 內徑 | AB | AH | AO | AU | E | EA | L | R | SA | T | TR | WH | XA |
|----------|----|------|----|----|------|-------|------|------|-----|---|----|----|----|
| 20 | 7 | 27 | 7 | 16 | 35.5 | 44.8 | 21 | — | 69 | 4 | 22 | 6 | 59 |
| 25 | 7 | 29 | 7 | 16 | 39.5 | 48.8 | 22 | — | 71 | 4 | 26 | 6 | 61 |
| 32 | 7 | 33.5 | 7 | 16 | 47 | 57 | 24.5 | 15 | 76 | 4 | 32 | 7 | 67 |
| 40 | 10 | 38 | 9 | 18 | 54.5 | 65.3 | 26 | 17.5 | 81 | 4 | 36 | 7 | 70 |
| 50 | 10 | 45 | 9 | 21 | 65.5 | 77.8 | 31 | 20 | 87 | 5 | 45 | 8 | 74 |
| 63 | 10 | 50 | 9 | 21 | 75.5 | 87.8 | 31 | 22.5 | 91 | 5 | 50 | 8 | 78 |
| 80 | 12 | 63 | 11 | 26 | 95.5 | 110.8 | 40 | — | 106 | 6 | 63 | 10 | 90 |

FAC

φ 20~φ 25

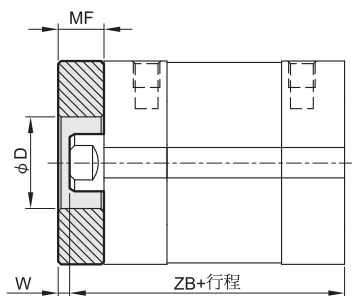
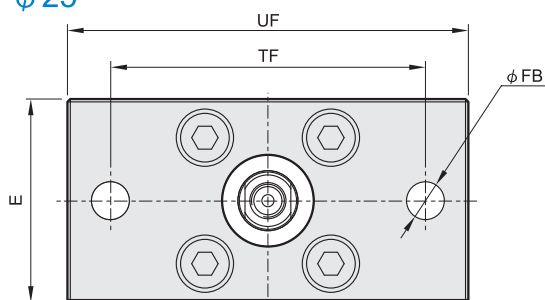

φ 32~φ 80

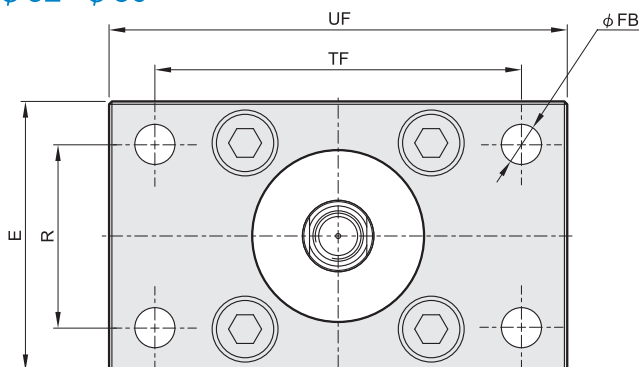

| 代號 內徑 | D | E | FB | MF | R | TF | UF | W | ZB |
|----------|----|------|-----|----|----|-----|-----|---|----|
| 20 | 16 | 35.5 | 6.6 | 8 | — | 55 | 70 | 2 | 43 |
| 25 | 16 | 39.5 | 6.6 | 8 | — | 60 | 76 | 2 | 45 |
| 32 | 30 | 47 | 7 | 10 | 32 | 64 | 80 | 3 | 51 |
| 40 | 35 | 54.5 | 9 | 10 | 36 | 72 | 90 | 3 | 52 |
| 50 | 40 | 65.5 | 9 | 12 | 45 | 90 | 110 | 4 | 53 |
| 63 | 45 | 75.5 | 9 | 12 | 50 | 100 | 120 | 4 | 57 |
| 80 | 45 | 95.5 | 12 | 16 | 63 | 126 | 150 | 6 | 64 |

FBC

φ 20~φ 25

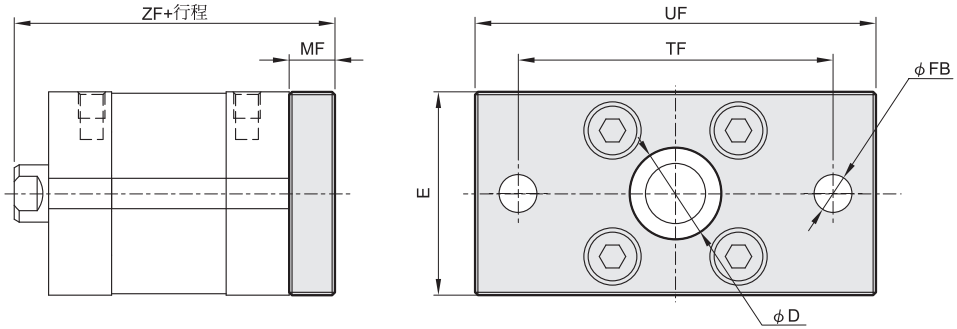

φ 32~φ 80

| 代號 內徑 | D | E | FB | MF | R | TF | UF | ZF |
|----------|----|------|-----|----|----|-----|-----|----|
| 20 | 16 | 35.5 | 6.6 | 8 | — | 55 | 70 | 51 |
| 25 | 16 | 39.5 | 6.6 | 8 | — | 60 | 76 | 53 |
| 32 | 30 | 47 | 7 | 10 | 32 | 64 | 80 | 61 |
| 40 | 35 | 54.5 | 9 | 10 | 36 | 72 | 90 | 62 |
| 50 | 40 | 65.5 | 9 | 12 | 45 | 90 | 110 | 65 |
| 63 | 45 | 75.5 | 9 | 12 | 50 | 100 | 120 | 69 |
| 80 | 45 | 95.5 | 12 | 16 | 63 | 126 | 150 | 80 |

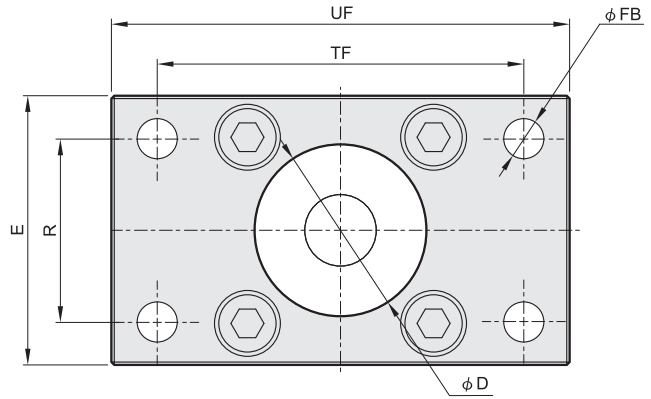

MP

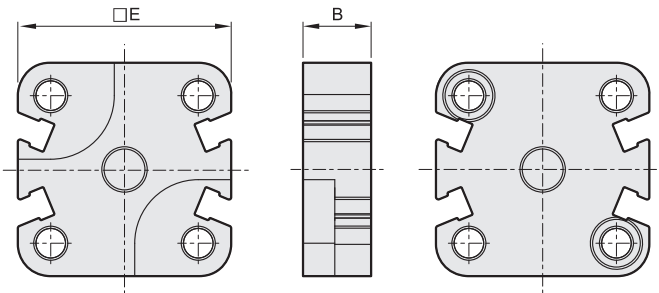

| 代號 內徑 | B | E | WH | ZA | 最大總行程 |
|----------|----|------|----|----|---------|
| 20 | 13 | 35.5 | 6 | 37 | 600 mm |
| 25 | 13 | 39.5 | 6 | 39 | 600 mm |
| 32 | 15 | 47 | 7 | 44 | 800 mm |
| 40 | 15 | 54.5 | 7 | 45 | 800 mm |
| 50 | 15 | 65.5 | 8 | 45 | 800 mm |
| 63 | 15 | 75.5 | 8 | 49 | 800 mm |
| 80 | 17 | 95.5 | 10 | 54 | 1000 mm |

※ 最大總行程為兩連接氣缸行程之總和。

內含零件：

| No. | 零件名稱 | 數量 |
|-----|--------|----|
| 1 | 雙頭型中座 | 1 |
| 2 | 定位銷 | 2 |
| 3 | 六角螺栓 | 2 |
| 4 | 六角承窩螺栓 | 2 |

