

**NEW**  
**MQL**  
**Oil-Mist**

**DA-E**<sup>®</sup>  
PNEUMATIC HYDRAULIC

**CS-4200 微量油霧潤滑系統**  
MICRO QUANTITATIVE OIL MIST LUBRICATION SYSTEM

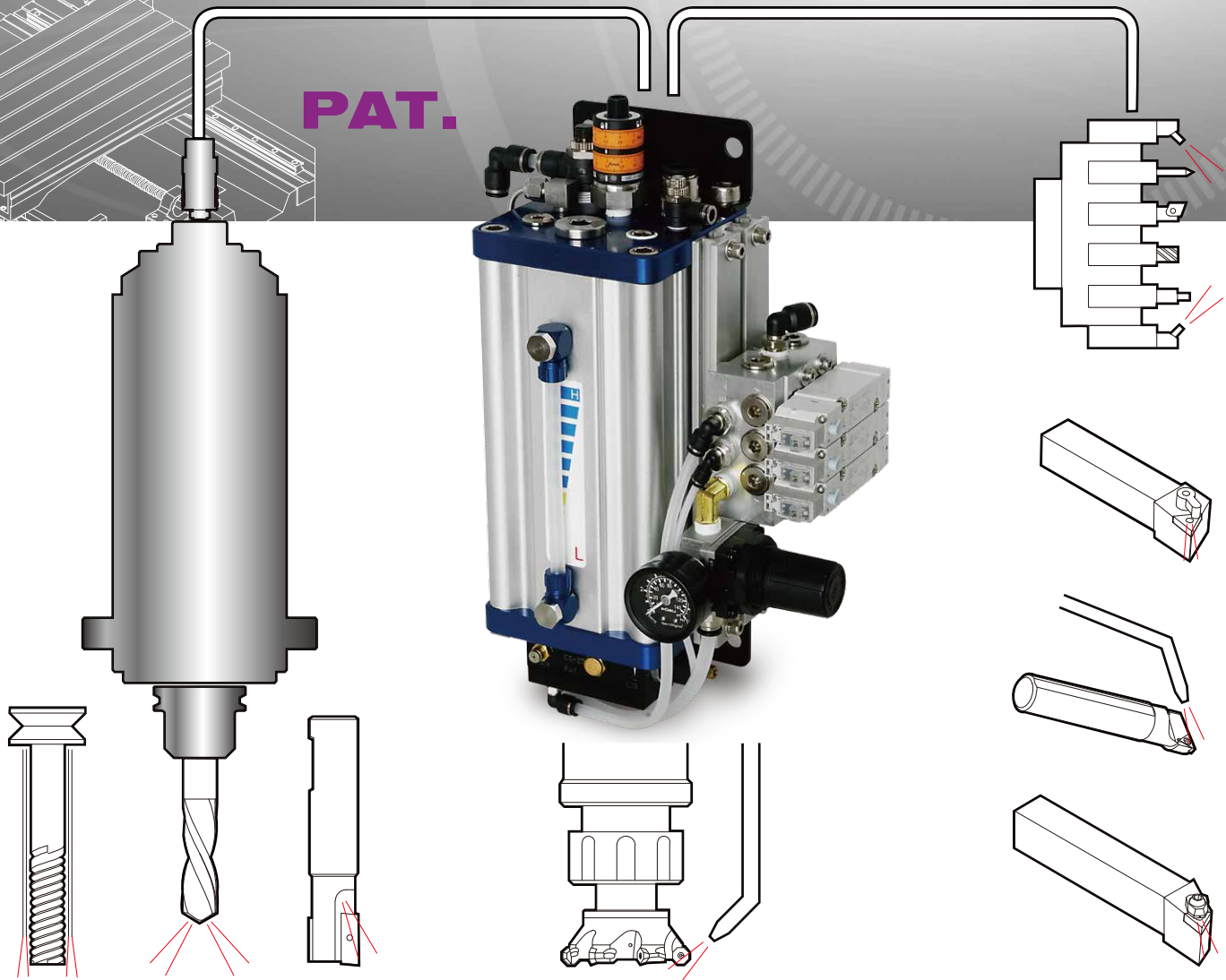

中心出油，耗油量低，該系統是將霧化的潤滑液通過加工機，穿過主軸的管道或數控車床中的管道，輸送霧化的潤滑液。

用上述方法將潤滑液塗在切削刃上，用噴嘴或帶油孔的工具，一起使用在深孔加工有良好的表現。

The oil is discharged from the center, and the oil consumption is low. The system is to pass the atomized lubricating fluid through the processing machine and through the main shaft. Pipes or pipes in CNC lathes deliver atomized lubricating fluids.

Apply the lubricating fluid to the cutting edge using the above method, use a nozzle or a tool with an oil hole, and use it together. It has good performance in deep hole processing.

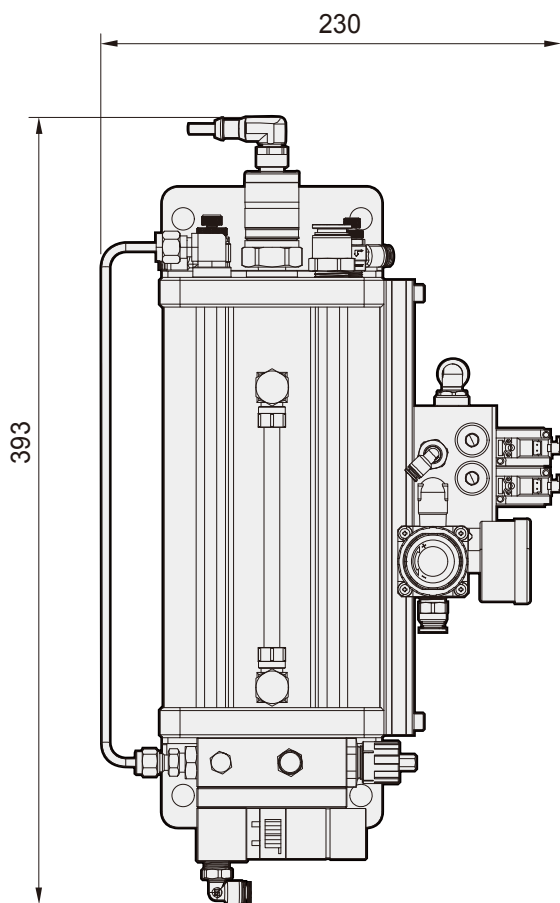
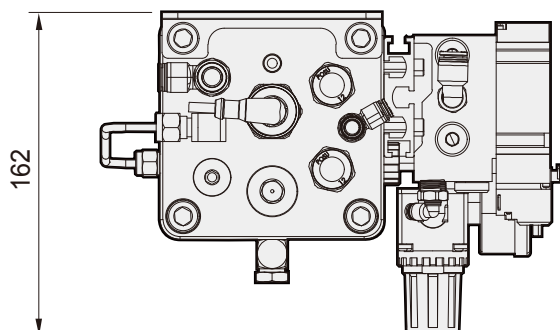

### 系統迴路 System Loop

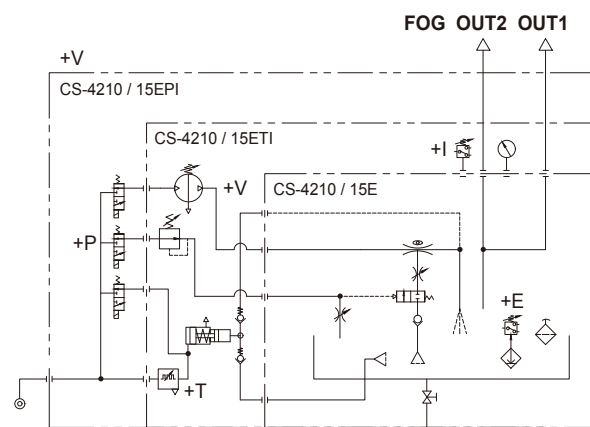

### 選用配件 Optional

#### VBA10A-02GN

氣體增壓系統

Gas pressurization system

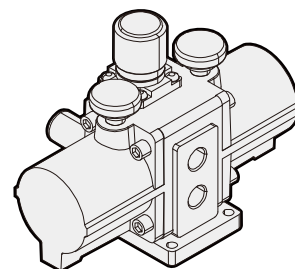

#### CS-040E

自動補油系統

Automatic oil replenishment system

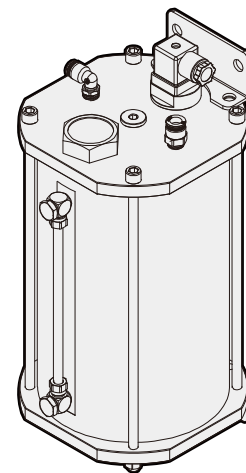

型號	CS-4210 ETI	CS-4215 ETI	CS-4210 EPI	CS-4215 EPI
使用壓力	0.4~1.0 MPa		0.4~1.0 MPa	
油量調節	手動設定		可程式設定	
內壓設定	手動設定		手動設定	
使用油品	Vascomill 22		Vascomill 22	
容量	1000 ml	1500 ml	1000 ml	1500 ml
重量	5.5 kg	6.0 kg	5.6 kg	6.1 kg